

THANK YOU FOR CHOOSING PANELTRONICS, INC. THIS WIRING DIAGRAM WILL Aid YOU IN THE INSTALLATION OF YOUR NEW PANEL. IT SHOULD BE KEPT FOR FUTURE REFERENCE AND SERVICE TO THE ELECTRICAL CONTROL PANEL WITH PROPER MAINTENANCE, YOU WILL ENJOY MANY YEARS OF RELIABLE OPERATION.

ALL PANELTRONICS PRODUCTS SHOULD BE USED AND INSTALLED IN ACCORDANCE WITH THE PROVISIONS OF THE NATIONAL ELECTRIC CODE, U.L. AND OTHER LOCAL, MILITARY OR INDUSTRY STANDARDS THAT ARE PERTINENT TO THE PARTICULAR END USE. IN MARINE INSTALLATIONS, ALL PANELS MUST BE INSTALLED TO MEET THE REQUIREMENTS OF U.S.C.G. 3309F, SUBPART 1, ELECTRICAL SYSTEMS, ON ALL BOATS THAT HAVE GASOLINE ENGINES FOR ELECTRICAL OR MECHANICAL POWER OR PROPULSION, EXCEPT OUTBOARD ENGINES. AERIAL BOAT AND YACHT COUNCIL (AERYC) STANDARDS AND RECOMMENDED PRACTICES SHOULD ALSO BE FOLLOWED.

PANELTRONICS INCORPORATED IS A COMPANY COMMITTED TO TOTAL QUALITY AND CONTINUOUS PRODUCT RESEARCH, DEVELOPMENT AND IMPROVEMENT, THEREFORE ALL INFORMATION AND SPECIFICATIONS ON THIS DIAGRAM ARE SUBJECT TO CHANGE WITHOUT NOTICE.

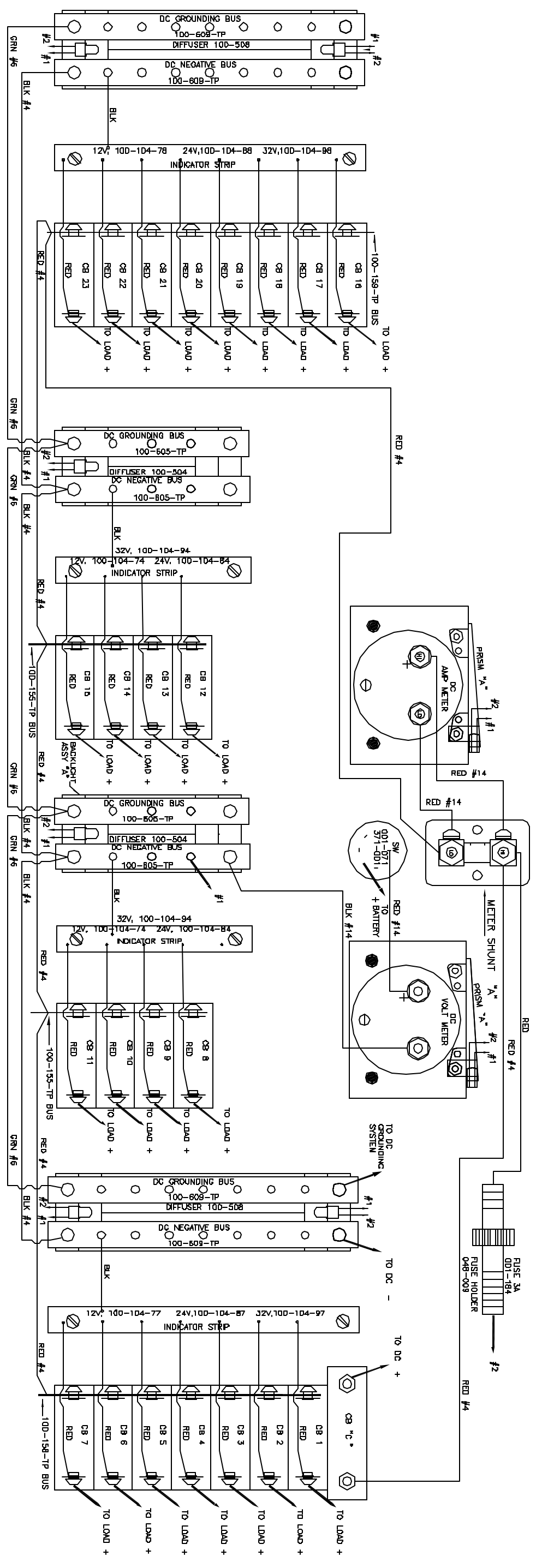

DC AMP METER	
RATING	PART NO.
50 DC A	289-012
50 DC A *	289-015
80 DC A	289-016
100 DC A	289-014
100 DC A	289-014
INTERNAL SHUNT	

DC VOLT METER	
RATING	PART NO.
B-16 VDC	289-017
B-32 VDC	289-017
D-30 VDC	289-024
D-30 VDC	289-024
INTERNAL SHUNT	

DC MAIN	
RATING	PART NO.
50A	208-028
80A	208-024
100A	208-025

DC AMP METER	
RATING	PART NO.
50 DC A	289-012
50 DC A *	289-015
80 DC A	289-016
100 DC A	289-014
100 DC A	289-014
INTERNAL SHUNT	

DC VOLT METER	
RATING	PART NO.
B-16 VDC	289-017
B-32 VDC	289-017
D-30 VDC	289-024
D-30 VDC	289-024
INTERNAL SHUNT	

DC MAIN	
RATING	PART NO.
50A	208-028
80A	208-024
100A	208-025

METER SHUNT "A"	
RATING	PART NO.
50 DC A	208-013
80 DC A	208-013
100 DC A	208-013

METER SHUNT "B"	
RATING	PART NO.
50 DC A	208-013
80 DC A	208-013
100 DC A	208-013

METER SHUNT "C"	
RATING	PART NO.
50 DC A	208-013
80 DC A	208-013
100 DC A	208-013

METER SHUNT "A"	
RATING	PART NO.
50 DC A	208-013
80 DC A	208-013
100 DC A	208-013

METER SHUNT "B"	
RATING	PART NO.
50 DC A	208-013
80 DC A	208-013
100 DC A	208-013

METER SHUNT "C"	
RATING	PART NO.
50 DC A	208-013
80 DC A	208-013
100 DC A	208-013

METER ILLUMINATION	
RATING	PART NO.
12V	100-248-7
24V	100-248-8
32V	100-248-9
32V	100-248-9

METER ILLUMINATION	
RATING	PART NO.
12V	100-248-7
24V	100-248-8
32V	100-248-9
32V	100-248-9

METER ILLUMINATION	
RATING	PART NO.
12V	100-248-7
24V	100-248-8
32V	100-248-9
32V	100-248-9

PANELTRONICS Rear View
 PNL, DC TWENTY-THREE (PREMIER)
 DC PANEL
 PANELTRONICS

4204

REV	DESCRIPTION	DATE
1	10-241 AND 1075 REVISION	8/24/87
2	REVISION 2: HORIZONTAL IN PHOTO UNCHANGED	11/22/87