

THANK YOU FOR CHOOSING PANELTRONICS, INC. THIS WIRING DIAGRAM WILL Aid YOU IN THE INSTALLATION OF YOUR NEW PANEL. IT SHOULD BE KEPT FOR FUTURE REFERENCE AND SERVICE TO THE ELECTRICAL CONTROL PANEL WITH PROPER MAINTENANCE, YOU WILL ENJOY MANY YEARS OF RELIABLE OPERATION.

ALL PANELTRONICS PRODUCTS SHOULD BE USED AND INSTALLED IN ACCORDANCE WITH THE PROVISIONS OF THE NATIONAL ELECTRIC CODE, U.L. AND OTHER LOCAL, MILITARY OR INDUSTRY STANDARDS THAT ARE PERTINENT TO THE PARTICULAR END USE. IN MARINE INSTALLATIONS, ALL PANELS MUST BE INSTALLED TO MEET THE REQUIREMENTS OF U.S.C.G. 33CFR SUBPART 1, ELECTRICAL SYSTEMS, ON ALL BOATS THAT HAVE GASOLINE ENGINES FOR ELECTRICAL OR MECHANICAL POWER OR PROPULSION, EXCEPT OUTBOARD ENGINES, AMERICAN BOAT AND YACHT COUNCIL (ABYC) STANDARDS, AND RECOMMENDED PRACTICES SHOULD ALSO BE FOLLOWED.

PANELTRONICS INCORPORATED IS A COMPANY COMMITTED TO TOTAL QUALITY AND CONTINUOUS PRODUCT RESEARCH, DEVELOPMENT AND IMPROVEMENT. THEREFORE ALL INFORMATION AND SPECIFICATIONS ON THIS DIAGRAM ARE SUBJECT TO CHANGE WITHOUT NOTICE.

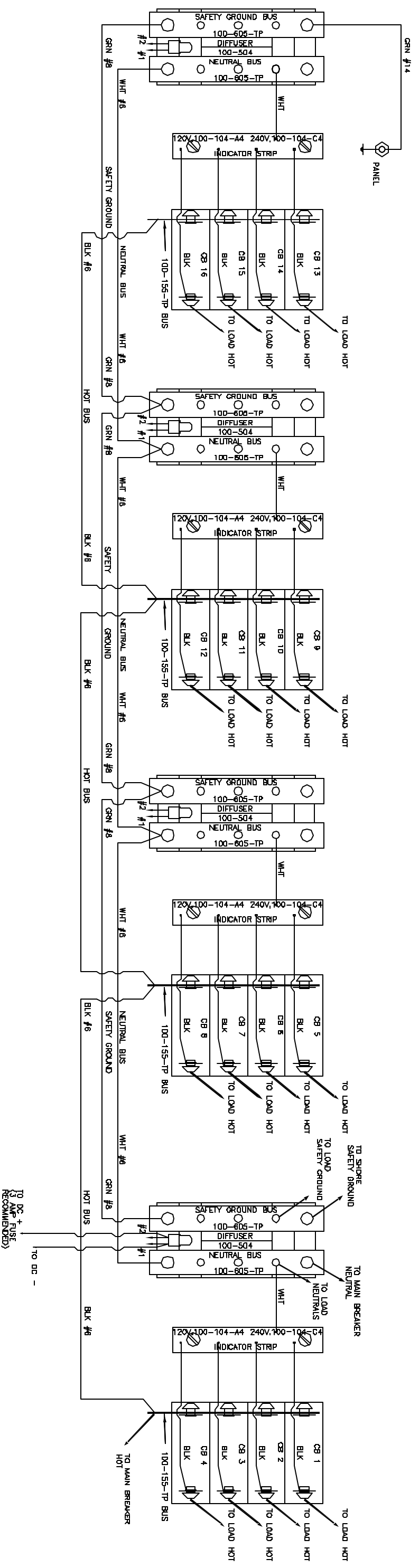

CB1 - CB16

RATING	PART NO.
5A	206-070S
10A	206-071S
15A	206-072S
20A	206-073S
25A	206-074S
30A	206-075S
40A	206-076S
50A	206-077S

BACKLIGHT ASSY "A"

RATING	PART NO.
1.2 VDC	100-243-7/R
2.4 VDC	100-243-8/R
3.2 VDC	100-243-9/R

**PANELTRONICS** Rear View AC Panel

REAR VIEW AC PANEL (PREMIER)

PANELTRONICS

4303

0