

REV.	DESCRIPTION	DATE	BY
0	100-243-8175 PANEL, AC EIGHT (PREMIER)	1/23/93	284118

THANK YOU FOR CHOOSING PANELTRONICS, INC. THIS WIRING DIAGRAM WILL AID YOU IN THE INSTALLATION OF YOUR NEW PANEL. IT SHOULD BE KEPT FOR FUTURE REFERENCE AND SERVICE TO THE ELECTRICAL CONTROL PANEL WITH PROPER MAINTENANCE. YOU WILL ENJOY MANY YEARS OF RELIABLE OPERATION.

ALL PANELTRONICS PRODUCTS SHOULD BE USED AND INSTALLED IN ACCORDANCE WITH THE PROVISIONS OF THE NATIONAL ELECTRIC CODE, U.L. AND OTHER LOCAL, MILITARY OR INDUSTRY STANDARDS THAT ARE PERTINENT TO THE PARTICULAR END USE. IN MARINE INSTALLATIONS, ALL PANELS MUST BE INSTALLED TO MEET THE REQUIREMENTS OF U.S.C.G. 33CFR SUBPART 1, ELECTRICAL SYSTEMS ON ALL BOATS THAT HAVE GASOLINE ENGINES FOR ELECTRICAL OR MECHANICAL POWER OR PROPULSION, EXCEPT OUTBOARD ENGINES. AMERICAN BOAT AND YACHT COUNCIL (ABYC) STANDARDS AND RECOMMENDED PRACTICES SHOULD ALSO BE FOLLOWED.

PANELTRONICS INCORPORATED IS A COMPANY COMMITTED TO TOTAL QUALITY AND CONTINUOUS PRODUCT RESEARCH, DEVELOPMENT AND IMPROVEMENT. THEREFORE ALL INFORMATION AND SPECIFICATIONS ON THIS DIAGRAM ARE SUBJECT TO CHANGE WITHOUT NOTICE.

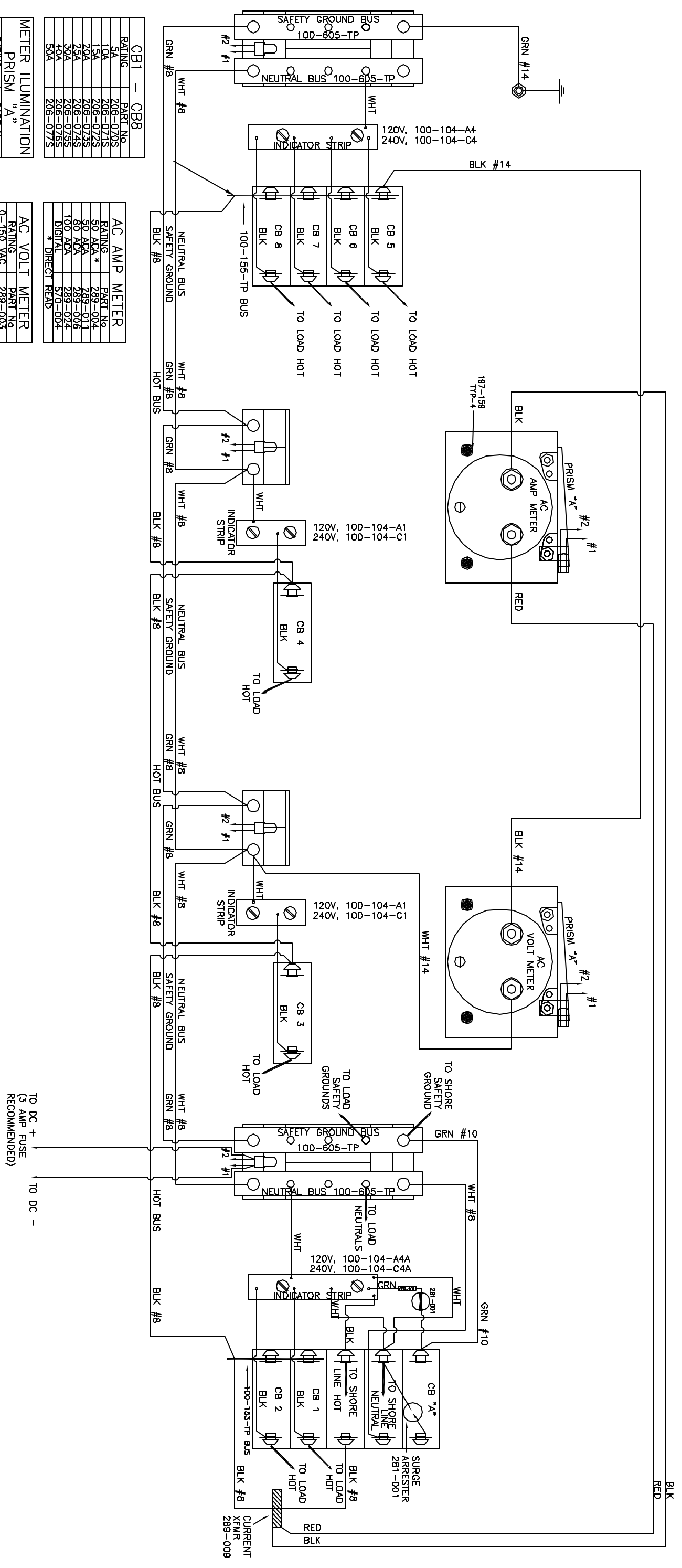

CB1 - CB8	
RATING	PART No
5A	206-070S
10A	206-071S
15A	206-072S
20A	206-073S
25A	206-074S
30A	206-075S
40A	206-076S
50A	206-077S

AC AMP METER	
RATING	PART No
50 A/A *	289-004
30 A/A	289-011
30 A/A	289-006
100 A/A	289-024
DIGITAL	570-004
* DIRECT READ	

METER ILLUMINATION	
PRISM "A"	
RATING	PART No
12 VDC	100-249-7
24 VDC	100-249-8
32 VDC	100-249-9

AC VOLT METER	
PRISM "A"	
RATING	PART No
0-150 VAC	289-003
0-300 VAC	289-007
DIGITAL	570-003

BACKLIGHT	
ASSY "A"	
RATING	PART No
12 VDC	100-243-7/R
24 VDC	100-243-8/R
32 VDC	100-243-9/R

SHORE MAIN	
CB "A"	
RATING	PART No
30A	206-087S
16A	209-086S

PANELTRONICS - Rear View, Inc.
 11800 NW 27th Court
 Hialeah, Florida, FL 33018
 (305) 881-1111
 FAX: (305) 881-1112

DATE: 02/23/93
 DRAWN BY: [Signature]
 CHECKED BY: [Signature]
 SCALE: 1X
 SHEET: CAT 4306 OF 0

PNL, AC EIGHT (PREMIER)
 PANELTRONICS