

THANK YOU FOR CHOOSING PANELTRONICS. THIS WIRING DIAGRAM WILL Aid YOU IN THE INSTALLATION OF YOUR ELECTRICAL PANEL. PLEASE REFER TO THE REVERSE SIDE OF THIS SERVICE TO THE ELECTRICAL CONTROL PANEL WITH PROPER MAINTENANCE. YOU WILL ENJOY MANY YEARS OF RELIABLE OPERATION.

ALL PANELTRONICS PRODUCTS SHOULD BE USED AND INSTALLED IN ACCORDANCE WITH THE RECOMMENDATIONS OF THE MANUFACTURER. THE MANUFACTURER'S INSTRUCTIONS OR INSTALLATION MANUALS SHOULD BE REFERRED TO FOR THE APPROPRIATE USE OF THE PRODUCTS. ALL PANELS MUST BE INSTALLED TO MEET THE REQUIREMENTS OF U.S.C.G. 33CFR SUBPART 1. ELECTRICAL SYSTEMS ON ALL BOATS THAT HAVE GASOLINE ENGINES, FOR ELECTRICAL OR MECHANICAL POWER OR PROPULSION, EXCEPT OUTBOARD ENGINES, AMERICAN BOAT AND YACHT COUNCIL (ABYC) STANDARDS AND RECOMMENDED PRACTICES SHOULD ALSO BE FOLLOWED.

PANELTRONICS INCORPORATED IS A COMPANY COMMITTED TO TOTAL QUALITY AND CONTINUOUS PRODUCT RESEARCH, DEVELOPMENT AND IMPROVEMENT. THEREFORE ALL INFORMATION AND SPECIFICATIONS ON THIS DIAGRAM ARE SUBJECT TO CHANGE WITHOUT NOTICE.

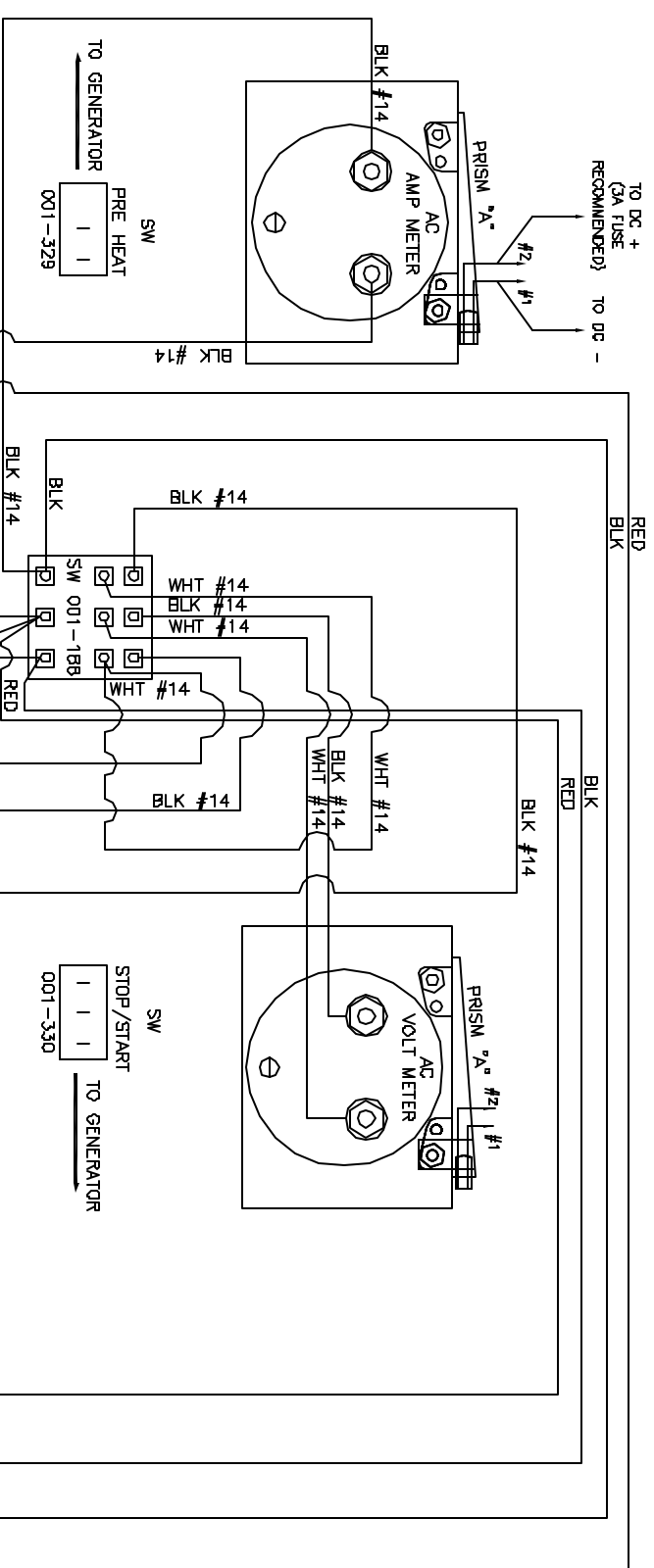

AC AMP METER		
RATING	PART No	
50 ACA	289-011	
80 ACA	289-006	
100 ACA	289-024	
DIGITAL	570-004	

AC VOLT METER		
RATING	PART No	
0-150 VAC	289-003	
DIGITAL	570-003	

GENERATOR CB "B"		
RATING	PART No	
30A	206-059	
40A	206-060	
50A	206-061	
60A	206-062	
80A	206-135	
100A	206-136	

METER ILLUMINATION PRISM "A"		
RATING	PART No	
12 VDC	100-249-7	
24 VDC	100-249-8	
32 VDC	100-249-9	

PLUG "A"		
COLOR	PART No	
BLACK	016-001	
WHITE	016-019	

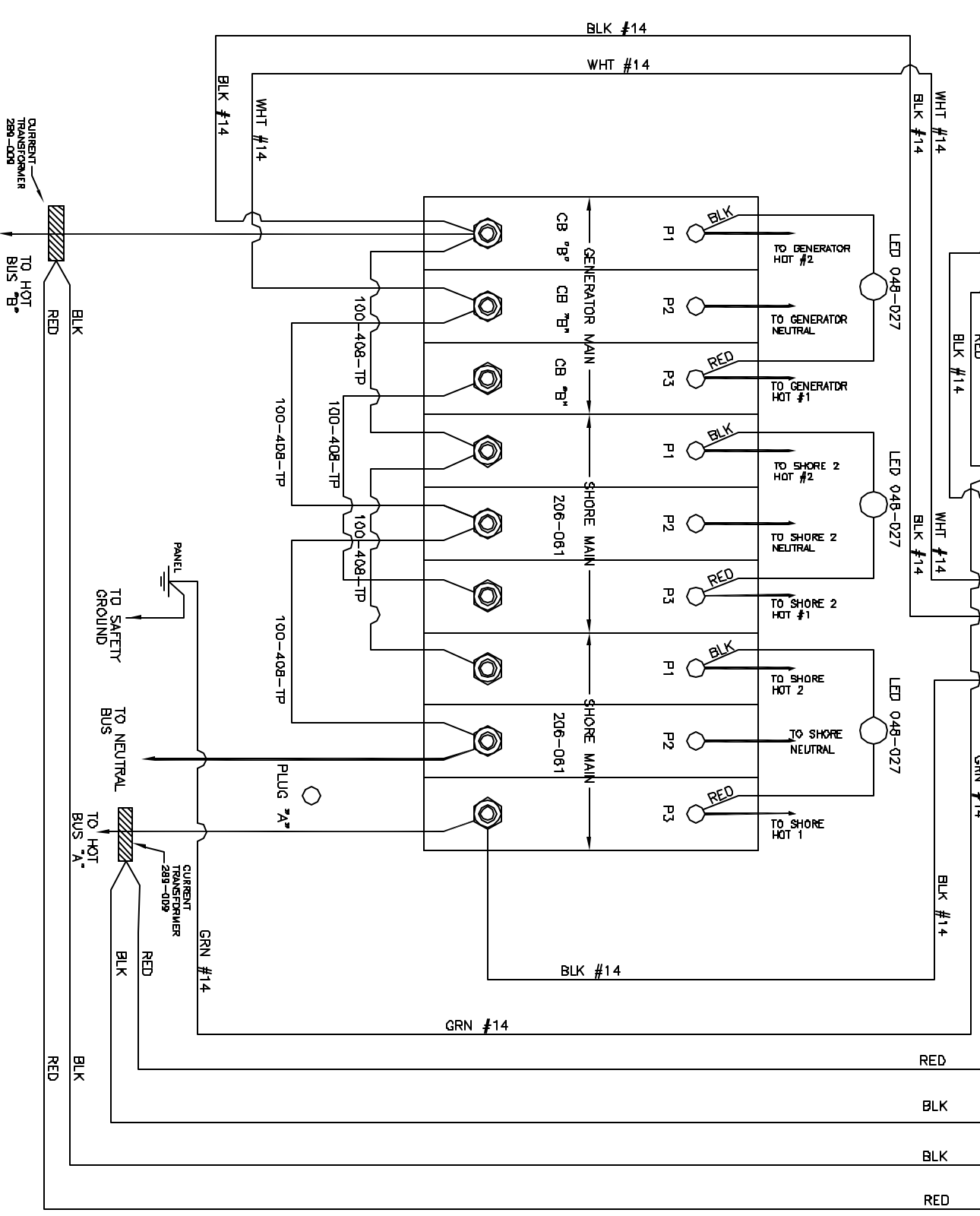

<b>PANELTRONICS</b> Paneltronics, Inc. 11800 NW 27th Court Hialeah, Florida, FL 33018	
REAR VIEW PNL, AC DUAL SHORE (PREMIER) AC PANEL PANELTRONICS	
DRAWING NO: 5307 DATE: 05/20/98 SHEETS: 1X SIZE: D	COMPANY: PANELTRONICS DRAWING #: 5307 REV: 0